

TPQR for TAKAYA

Visualize your test program coverage

Test Program Quality Report for Takaya is a member of the new generation of “easy to use” test coverage analysis tools provided by ASTER. It has been developed in association with ASTER’s partner.



It allows users to independently compute and visualize the test coverage provided by the TAKAYA flying probe tester (APT8000 & APT9000).



BOARD DATA

The TestExpert FATF file (complete with device.asc, labelset.asc and nails.asc) or the CAMCAD CCZ file used for test program generation, are

imported by TPQR in order to visualize the board layout and modelize components class and properties such as part number, value, tolerance.

COVERAGE ANALYSIS

By directly importing the TAKAYA test program in either the CA8, CA9, TA8, APTTEXT and ATD test program formats, TPQR analyzes the data and computes the test coverage.

The coverage analysis is based on the industry standard TestWay analyzer. It checks the ability of each test step to catch certain defects based on component type, value, tolerance and board connectivity.

ADVANCED REPORTS

The results are presented in a precise and explicit format. It includes a top level overview with the parts grouped by component type; the number of parts or pins; the percentage of devices fully tested; the percentage of devices partially tested and the percentage of devices that are not tested.

Each device can be expanded to show individual information by pin; signal name; the type of test and whether each pin is tested.

Key product benefits:

- Ease of Use**
 Visualize the test coverage provided by the TAKAYA flying probe tester, by simply importing the test program.
- Scalable-License migration**
 Convert the TPQR configuration into TestWay Express or TestWay, enabling more sophisticated analysis capabilities.
- Native Takaya program**
 Support both APT8000 and APT9000 within any pre-debug format or post-debug format.
- Coverage Analysis**
 Powered by TestWay, the world-wide reference coverage tool, helping users to quantify and qualify test coverage. It is designed for use by board manufacturers (CMs) and their customers (OEMs), for providing precise, detailed and impartial test coverage metrics.
- TestExpert & CAMCAD support**
 The projects used for test program generation are imported by TPQR in order to modelize & visualize board layout.
- Comprehensive Reports**
 Create HTML reports for test coverage, presented as a board level overview, or as explicit coverage information on selected items. The reports have been designed to be navigated by a simple Internet browser that allows users to share advanced interactive reports throughout design & test organizations.
- MS-Excel spreadsheet**
 Excel report indicates the ability to detect device Presence, Polarity, Value and Solder defects for each part.
- Color assignment**
 Visualize test coverage on components and pins using the “traffic light” color coding.
- Fully Interactive Cross-probing**
 Enables fully interactive cross-probing between test coverage reports and board view.

TEST REPORT FOR TAKAYA FLYING PROBER				
BOARD NAME / NUMBER		TAKAYA	DATA PROCESSING REPORT	
NET ACCESS		62.09%	WRK:TAKAYA.htm	
PART	TOTAL NUMBER (PARTS OR PINS)	Number of well tested	Number of partially tested	Number of not tested
Not identified	2 Parts	0.0% (0)	0.0% (0)	100.0% (2)
Integrated Circuit	6 Parts (124 Pins)	0.0% (0)	66.7% (4)	33.3% (2)
Transistor	9 Parts	0.0% (0)	11.1% (1)	88.9% (8)
Diode	2 Parts	100.0% (2)	0.0% (0)	0.0% (0)
LED	19 Parts	100.0% (19)	0.0% (0)	0.0% (0)
Capacitor	20 Parts	100.0% (20)	0.0% (0)	0.0% (0)
Resistor	41 Parts	46.3% (19)	4.9% (2)	48.8% (20)
Fuse	1 Parts	100.0% (1)	0.0% (0)	0.0% (0)
Inductor	2 Parts	100.0% (2)	0.0% (0)	0.0% (0)
Strap	3 Parts	66.7% (2)	0.0% (0)	33.3% (1)
Connector	3 Parts (23 Pins)	0.0% (0)	0.0% (0)	100.0% (3)
Test point	66 Parts			
Total	108 Parts (66 ignored)	60.2% (65)	6.5% (7)	33.3% (36)



ASTER Technologies

TPQR is built around the core of the industry leading **QuadView**, suite of next generation viewers. This powerful layout and schematic viewer allows users to visualize coverage at both device and pin level, with fully interactive cross-probing between all views.

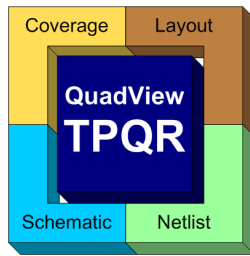

COVERAGE VISUALIZATION

Detailed coverage information presented in the reports, can interact directly with the layout and schematic viewer in order to identify components and pins with inadequate or poor coverage. Simply click-on the component reference or device pin number to link directly to the component in either the layout or schematic views. In order to make the coverage easy-to-interpret, the colors of a traffic light are used:



Red Not tested
Orange Partially tested
Green Well tested

LAYOUT VIEWER

The layout view is created from the data used to generate the TAKAYA test program such as CAMCAD, FATF. The layout view can be flipped or rotated to visualize either the top or bottom side. Component body, pad, layer, trace, via and test probe location colors can be individually selected.

SCHEMATIC VIEWER

QuadView has a unique digitization capability that allows users to create the schematic view directly from a searchable PDF file.

Schematic views can also be created from other standard formats such as HPGL and Windows Metafile etc.

NETLIST NAVIGATOR

The innovative “Netlist Navigator” provides a virtual schematic view reconstructed directly from a netlist, which allows users to navigate easily through complex schematic hierarchy. It also provides a unique capability to visualize component pin functionality using advanced graphical symbols.

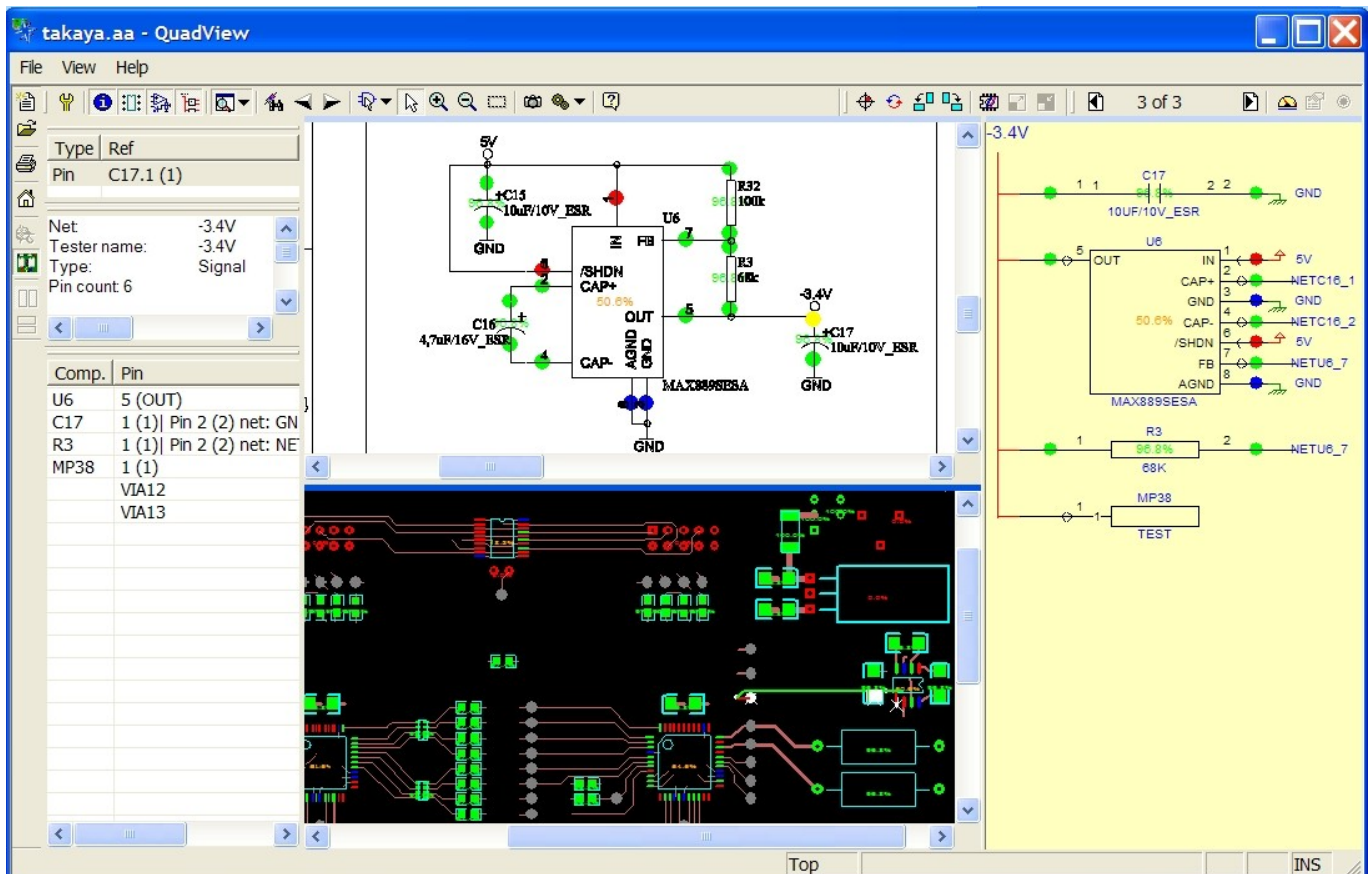

Visit our web site at www.aster-technologies.com for the latest product news.

Copyright © 2008 ASTER Technologies. TestWay, QuadView, QuadView-TPQR and QUAD are trademarks of ASTER Technologies. All other trademarks mentioned in this document are trademarks of their respective owners.



PA du long Buisson
 260 rue Clément Ader
 27000 Evreux
 France
 phone : +33 (0) 2 32 35 64 80
 fax : +33 (0) 2 32 35 00 66
software@accelonix.fr



ASTER Technologies

Corporate Headquarters

ASTER Technologies

55 bis, rue de Rennes

F35510 Cesson-Sevigne

France

Phone: +33 (0)2 99 83 01 01

Fax: +33 (0)2 99 83 01 00

sales@aster-technologies.com